

GE series on-line radiometric coal quality analyzers for coal excavation, processing and combustion optimization



The analyzers allow monitoring of actual coal quality online directly on the belt conveyor, can determine the calorific value, ash content and flow rate within specified time interval. Use of the units will improve the excavation efficiency and allow optimization of coal consumption which leads to significant cost reduction. The content of non-combustibles is evaluated based on attenuation of dual gamma radiation. The measurement method conforms to all nuclear safety regulations.

The GE3000 series coal analyzers represent the third generation of Enelex on-line radiometric analyzers. Its evolution utilizes more than 25 years of practical experience and knowledge in the field of contactless coal quality monitoring and also needs of our important customers.

Advantages

- Immediate information on measured coal quality and quantity
- Works without granularity restriction – from dust up to ROM coal
- Allows integration into the complex Coal Quality Management Systems (CQMS)
- Adaptable graphical interface for intelligible readings of calorific value, ash content and coal quantity / flow rate.
- Fast response time enables utilization during high conveyor speed or flow rate fluctuation
- Direct measurement on belt conveyor, no crushing needed
- Direct measurement at transfer points
- Direct measurement in chutes and pipes
- Measurement in explosive environment
- Quick, simple and accurate calibration, possible switching of distinct fuel types
- Simple installation on belt conveyor frame using clamps and bolts, no drilling / cutting / welding needed
- Does not interfere normal operation of transportation technology
- No contact with coal in motion
- Operation is independent on layer fluctuation on belt conveyor
- Highly resistant to vibrations and mechanical tension
- Highly resistant to electric and electromagnetic noise
- Multi-language user interface
- Fully secured in terms of nuclear safety
- Alternatively can evaluate other materials based on organic carbon
- Extremely low maintenance requirements if integrated to CQMS

Analyzer operation

- On-line calorific value evaluation in MJ/kg or kcal/kg
- On-line ash percentage evaluation
- On-line monitoring of coal quantity (flow rate) in t/h
- On-line monitoring of material layer height on the belt conveyor in mm
- Device calibration for 12 different coal types with possible extension
- Measurement in three independent time frames (online value, input activated time interval, preset shift-wise time interval)
- Control stage touchscreen user interface with both numeric and graphic result presentation
- LAN network connection for remote monitoring, data transfer, archiving and system maintenance.
- Direct data push to control system SQL database
- Industrial grade 4 – 20 mA analog outputs
- Automatic measurement blocking in case of conveyor stop
- Internal battery backup to cover short term power outages
- Automatic unit startup after power failure

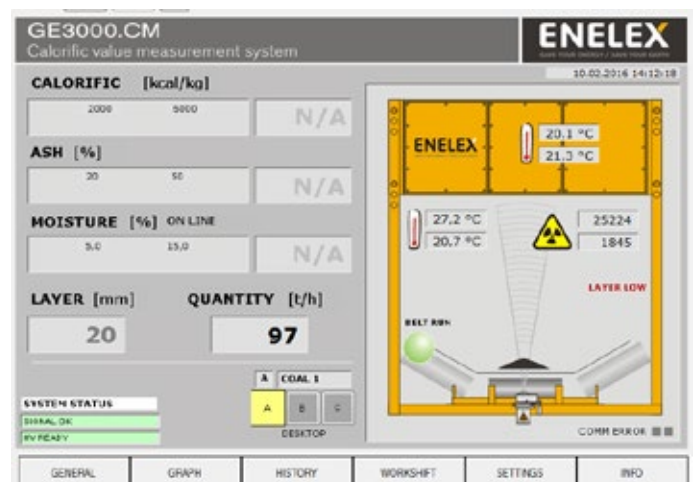

GE3000 versions and features

	GE3000	GE3000.CM	GE3000.EX	GE3030
Calorific value evaluation	•	•	•	•
Ash content evaluation	•	•	•	•
Coal quantity monitoring	•	•	•	–
Coal layer monitoring	•	•	•	–
Unit calibration for 12 different coal types	•	•	•	•
Direct measurement on belt conveyors	•	•	•	–
Direct measurement on transfer points	•	•	–	–
Direct measurement in chutes and piping	•	•	–	–
Bolt-fixed frame for belt conveyor	•	•	–	–
Use in preparation rooms or laboratories	–	–	–	•
Possible installation on excavation machines	•	–	–	–
Use in explosive environment	–	–	•	–
Individual moisture measurement stage	–	•	–	–
Realtime measurement (on-line)	•	•	•	–
Time interval measurement (batch mode)	•	•	•	–
Automatic generation of measurement protocol	–	–	–	•
Presentation of measurement history in form of graph	•	•	–	–
Presentation of measurement history in numeric form	•	•	–	•
LAN network connection to superior systems	•	•	•	•
SQL database push to superior systems	•	•	•	•
4 – 20 mA industrial grade analog outputs	•	•	•	–
Automatic blocking of measurement during conveyor stop	•	•	•	–
Backup for short power feed drops	•	•	–	–
Automatic startup after power failure	•	•	•	•
Multi-language interface	•	•	•	•
Remote control and diagnostics	•	•	•	•

Installation on belt conveyor frame using clamps and bolts



Application examples

Excavation control in open-pit mine

The online analyzers installed directly on mining excavators can verify whether the actual coal quality agrees to expected parameters and adjust the excavation scenario accordingly. The resulting quality is measured on the main run-of-mine conveyors. Based on on-line measurement there can be determined the stockpiling strategy. The quality of stacked coal is monitored by the on-line analyzers on stacker/reclaimers. In reclaiming process the system can verify the resulting quality of coal delivery. The GE3000 series analyzers can be utilized in control of sorting flap-gates for immediate quality based redirection. In case of change in coal quality the flap-gate can redirect the good quality material to direct dispatching (e.g. export coal) but the reject coal can be diverted for separate storage. During coal dispatch the GE3000 series online analyzers monitor the coal quality in respect to customer requirements. The actual balance is monitored during outloading process. The overall batch quality can be corrected by addition of different quality coal in case of non-fulfilment of requirements.

Coal analysis in underground mines

The online analyzers are used for monitoring of coal quality coming from different mine sections for excavation control. The ATEX certified version of online analyzer can be placed directly in underground tunnels.

Coal analysis in power stations

For power plant coal feed control the GE3000 series online analyzers are installed on the inlet belt conveyors. Based on on-line measurement there can be determined the stockpiling strategy. The quality of stacked coal is monitored by the on-line analyzers on stacker/reclaimers. In reclaiming process the system can verify the resulting quality of feeding coal. Analyzers installed on plant feed conveyors monitor the coal quality before the feeding bunkers. The coal can be sorted to different bunkers based on quality parameters and consequently the whole quality range of input coal can be blended for optimized combustion.

Coal analysis in washing plants

The coal washeries can use the online analyzers directly for process control. There is measured not only input and output coal quality but also midlings in process of washing. The operator has all the quality information available in real time so that operative decisions can be taken immediately. The GE3000 series on-line analyzers installed at the cyclone or separator output monitor the parameters of wet coal. It is used for direct process control. In case of deviation from required parameters the system will automatically control the washing media to become thicker or thinner. To monitor the efficiency of washing processes there are also online monitored the parameters of rejects.

Transshipment and distribution

By help of GE3000 series on-line analyzers it is verified whether the quality of the coal is in line with declared parameters at the site input and also at the output just before outloading.

Special applications

- Installation on reject belt of coal sampler
- Measurement of unburned content in solid ash
- Measurement of quality of oil shales or other materials
- Measurement of coke and coking blends

GE3000

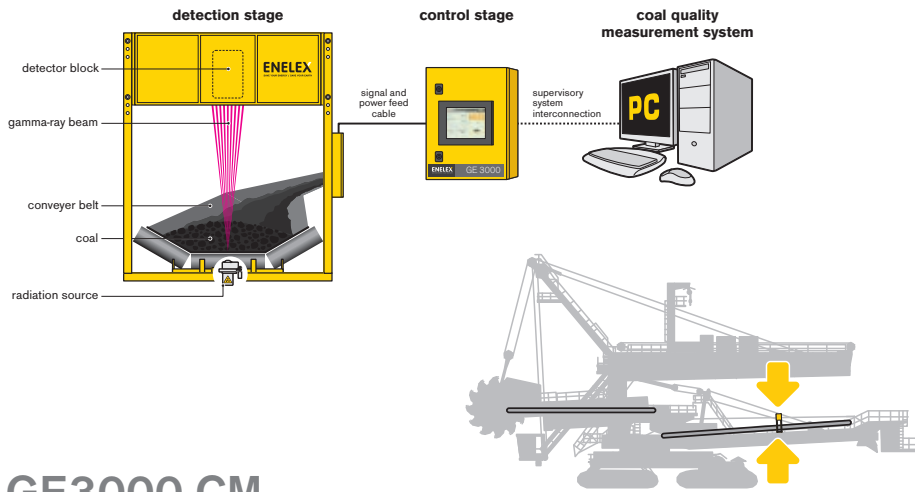

GE3000.CM

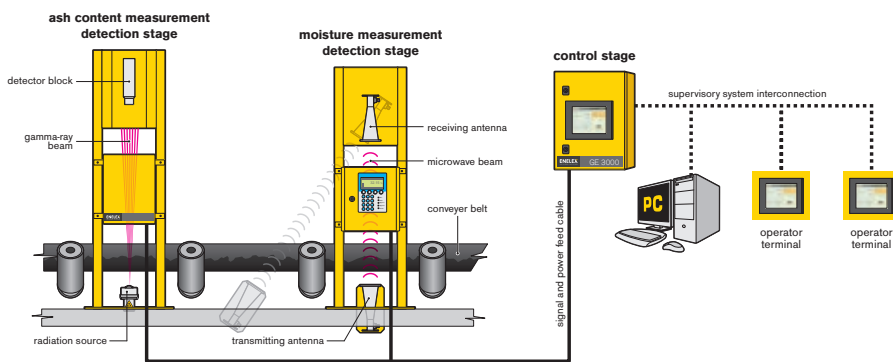

Control of sorting flap-gates

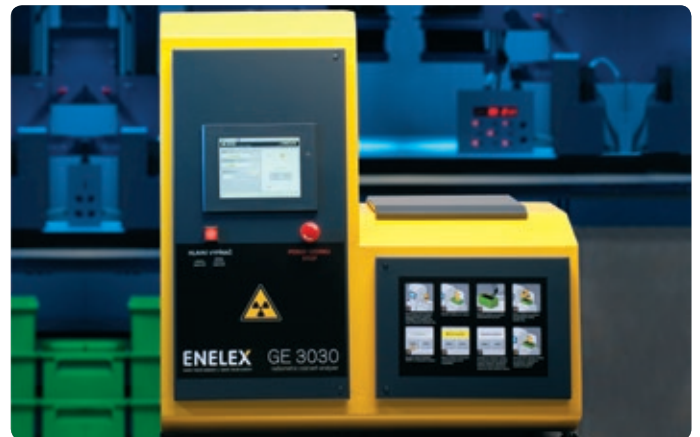
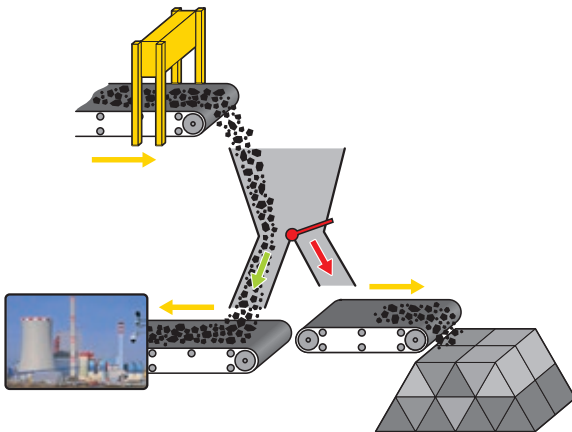

Measurement in chutes and pipes

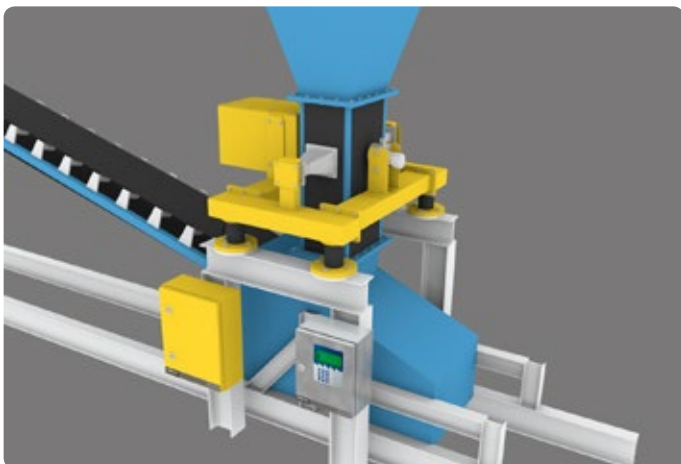

GE 3030 in-service rapid coal analyzer

The GE 3030 allows quick determination of ash content in given coal samples directly on site, eventually in laboratories. This allows to taking operative decisions and significantly improve efficiency of operations and economy.

The content of non-combustibles is evaluated based on attenuation of gamma radiation of two different energies. The device is in desktop design. The complete measurement unit is integrated in single casing and the operator does not manipulate with the sample inside the radiation beam. Control and setup of the unit is performed using the touchscreen operator panel. The use of the unit is simple so that no special training is necessary for operators.

Basic technical parameters

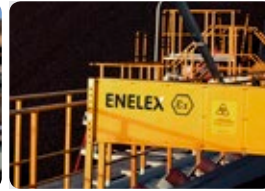

	GE3000	GE3000.CM	GE3000.EX	GE3030
Belt width	unlimited	unlimited	unlimited	-
Conveyor speed	unlimited	unlimited	unlimited	-
Coal granularity*	unlimited	0 – 90 mm	unlimited	0 – 20 mm
Coal layer*	40 – 350 mm	40 – 300 mm	40 – 250 mm	Approx. 100 mm in sample container
Measurement range	As required	As required	As required	As required
Response time	Adjustable (typ. 1 min)	Adjustable (typ. 1 min)	Adjustable (typ. 1 min)	3 – 10 min
Quantity of measured material	As per belt conveyor	As per belt conveyor	As per belt conveyor	Approx. 2 kg in sample container
Accuracy of ash content determination	Better than ± 1,0 %	Better than ± 1,0 %	Better than ± 1,0 %	Better than ± 0,5 %
Power feed	230 V, 50 Hz, 100 VA	230 V, 50 Hz, 200 VA	230 V, 50 Hz, 100 VA	230 V, 50 Hz, 100 VA
Protection level (control stage)	IP54/IP65	IP54/IP65	ExI M2 (ATEX)	IP54
Protection level (detection stage)	IP65	IP65	ExI M2 (ATEX)	IP54
Working temperature (control stage)	0 °C / +50 °C	0 °C / +50 °C	0 °C / +50 °C	0 °C / +50 °C
Working temperature (detection stage)	-40°C / +50 °C	-40°C / +50 °C	-40°C / +50 °C	0 °C / +50 °C
Outputs*	<ul style="list-style-type: none"> • 4x analog 4 - 20 mA, galvanic insulated each, output parameter selectable • 5x digital passive, output parameter selectable • RS485 ModBus RTU • LAN 	<ul style="list-style-type: none"> • 4x analog 4 - 20 mA, galvanic insulated each, output parameter selectable • 5x digital passive, output parameter selectable • RS485 ModBus RTU • LAN 	<ul style="list-style-type: none"> • 4x analog 4 - 20 mA, galvanic insulated each, output parameter selectable • 5x digital passive, output parameter selectable • RS485 ModBus RTU • LAN 	<ul style="list-style-type: none"> • RS485 ModBus RTU • LAN • USB pendrive
Inputs	<ul style="list-style-type: none"> • 4x analog voltage, input parameter selectable • 4x digital passive (max 40VDC or 24VAC), input parameter selectable 	<ul style="list-style-type: none"> • 4x analog voltage, input parameter selectable • 4x digital passive (max 40VDC or 24VAC), input parameter selectable 	<ul style="list-style-type: none"> • 4x analog voltage, input parameter selectable • 4x digital passive (max 40VDC or 24VAC), input parameter selectable 	N/A
Radiation sources	²⁴¹ Am max.11,1GBq, ¹³⁷ Cs max. 0,37GBq	²⁴¹ Am max.11,1GBq, ¹³⁷ Cs max. 0,37GBq	²⁴¹ Am max.11,1GBq, ¹³⁷ Cs max. 0,37GBq	²⁴¹ Am max.11,1GBq, ¹³⁷ Cs max. 37MBq
Microwave power output	N/A	< 1 mW	N/A	N/A
Radiation source container type	CsAm 20W (wolfram shielding insert)	CsAm 20W (wolfram shielding insert)	CsAm 20W (wolfram shielding insert)	CsAm 25W (wolfram shielding insert)
Radiation source container weight	8 kg	8 kg	8 kg	11 kg
Dimensions (control stage) WxHxD	400x500x170 mm	400x500x170 mm	940x580x250 mm	800 x 850 x 600 mm
Dimensions (detection stage)	As per belt conveyor	As per belt conveyor	As per belt conveyor	800 x 850 x 600 mm
Weight (control stage)	15 kg	15 kg	75 kg	75 kg
Weight (detection stage)	As per belt conveyor (typ. 120 kg)	As per belt conveyor (typ. 120 kg)	As per belt conveyor (typ. 180 kg)	75 kg

* other options available on request



Nuclear safety

The detection stage is designed with strong focus on maximum safety and reliability. The radionuclides are placed in easily transportable shielding container made of wolfram and stainless steel to ensure its endurance even in case of fire or other extraordinary situation. In inoperative position the shielding container allows safe transport and storage with no need of removal or manipulation with the radionuclides. By setting the container to working position the radiation beam is directed through the belt conveyor only while presence of personnel beside the belt conveyor is not limited.



TAURUS POWERTRONICS PVT LIMITED

Corp. Off.: No. 26, "Mahadimane", 12th Main, 1st Block, Rajajinagar, Bengaluru - 560 010. INDIA., Tel : + 91 80 2301 2301

Email : info@tauruspowertronics.com, enquiry@tauruspowertronics.com, WhatsApp : +91 73496 44344

Sales & Service Off.: No. 648/54, KLE College 2nd Block, Rajajinagar, Bengaluru - 560 010. INDIA , Tel : + 91 80 2352 2136/74

BENGALURU

DELHI

KOLKATA

MUMBAI

www.tauruspowertronics.com